

## Foot Mounted Electric Wire Rope Hoist

### Hoist model VAT4522TpE3N

Capacity - 10 tonne in FEM9.511 - 2m  
 Lifting Height - 9m  
 Lifting Speed - 4.8/1.2 m/min  
 Voltage - 230, 460, 575V-3ph-60Hz  
 Rope Reeving - 4/1

### Lifting Motor model KV4003P-24/6

Rated power - 2.0/9.6 kW  
 Switches per hour - 300h-1

Net Weight - 685kg

Mechanical overload protection (OL)

Optional thermal overload protection (Tp)

Electric panel not shown

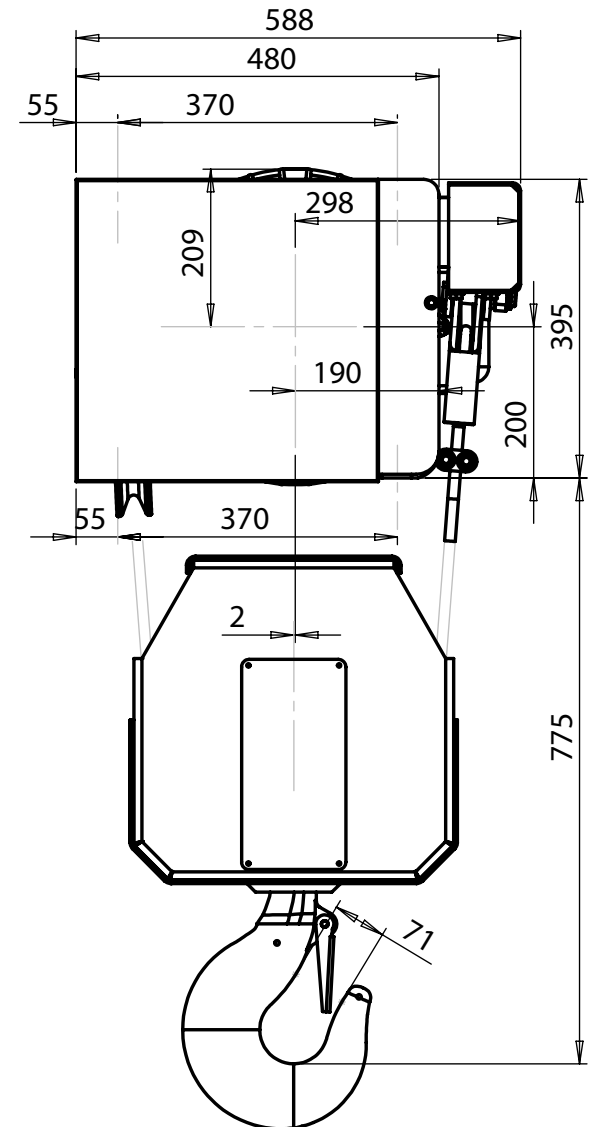
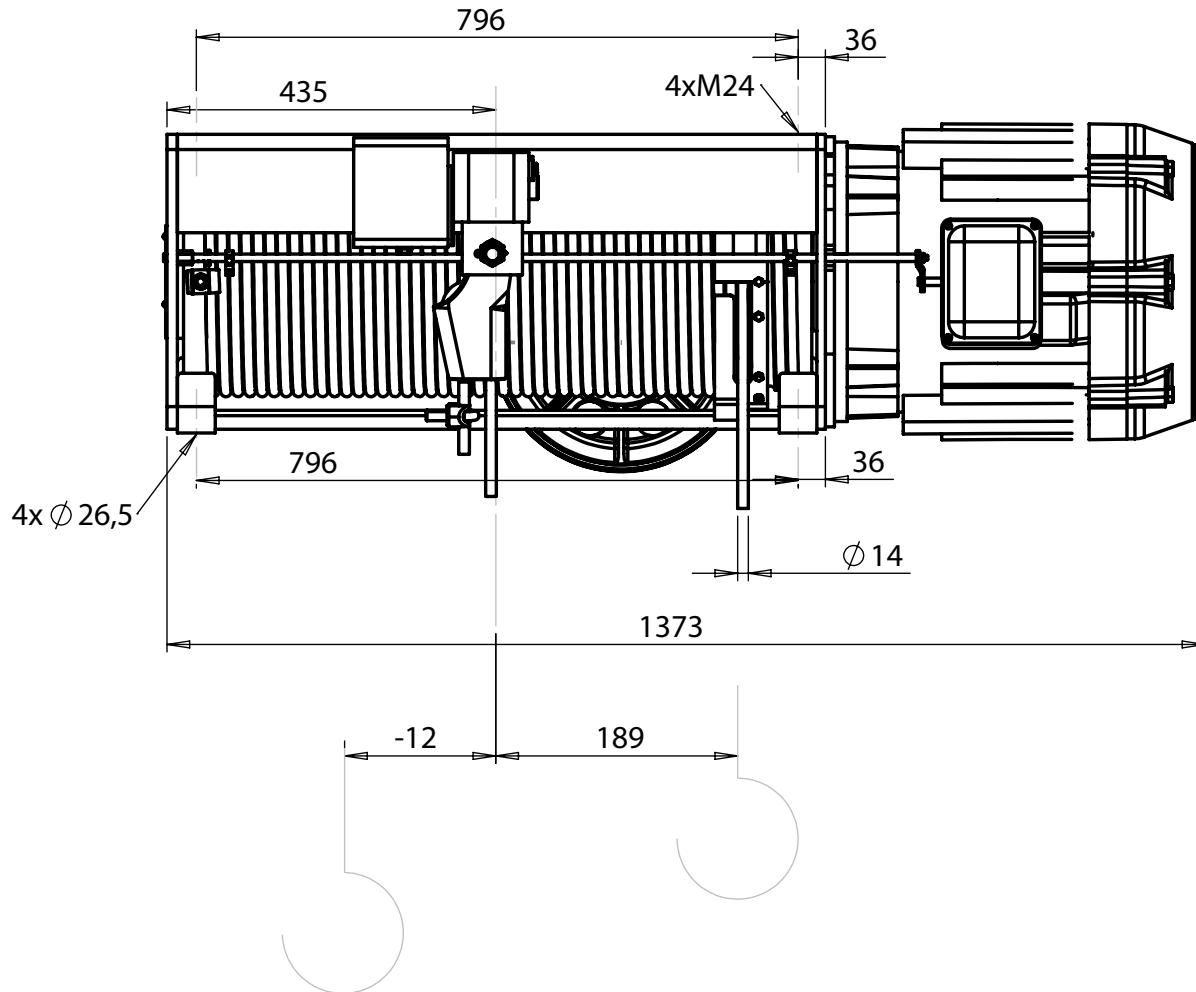

t 604 796 9221 e integrity@hydramachcrane.com  
 f 604 796 9227 www.hydramachcrane.com

\*Dimensions and specifications subject to change without notice.